

Figur 1. Kontrollmall för höjdmätning av fotoceller i startområdet

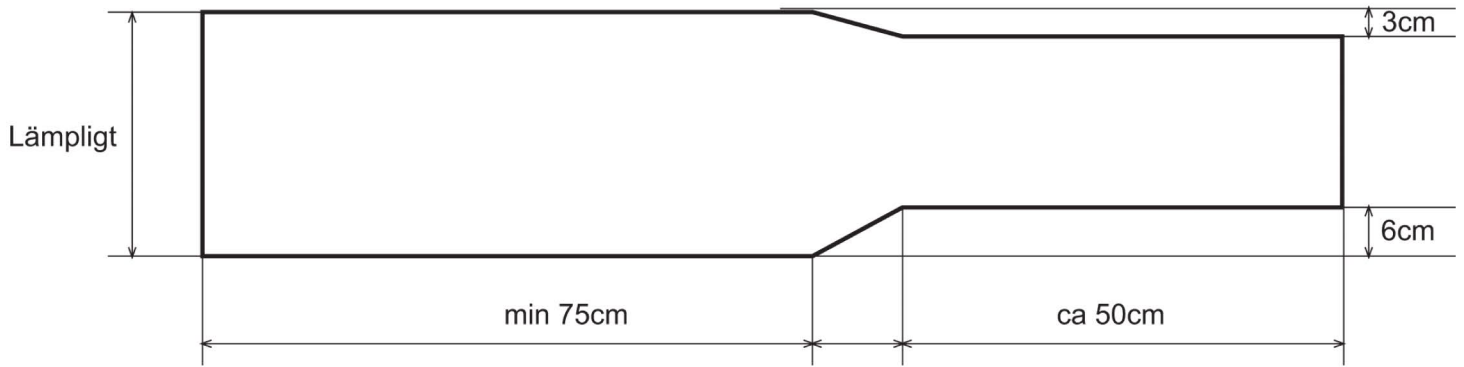

Figur 2. Kontrollmall för mätning av roll out

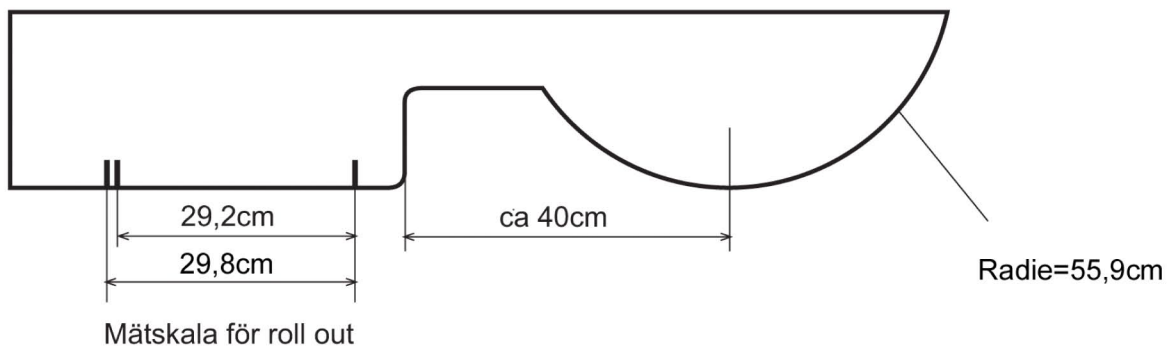

Figur 3. Mätpunkter startområde

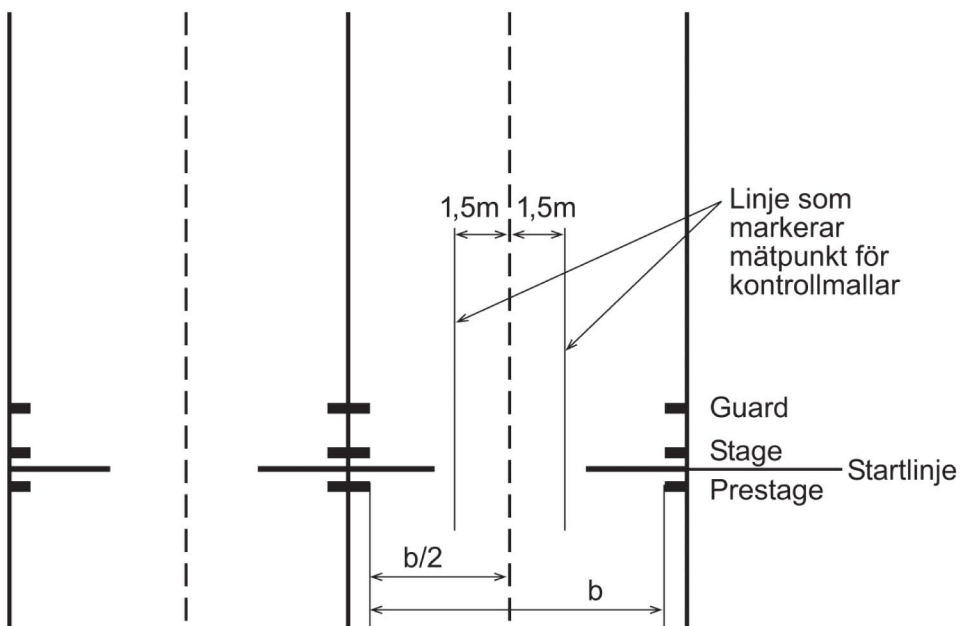

Figur 4. Startgranen

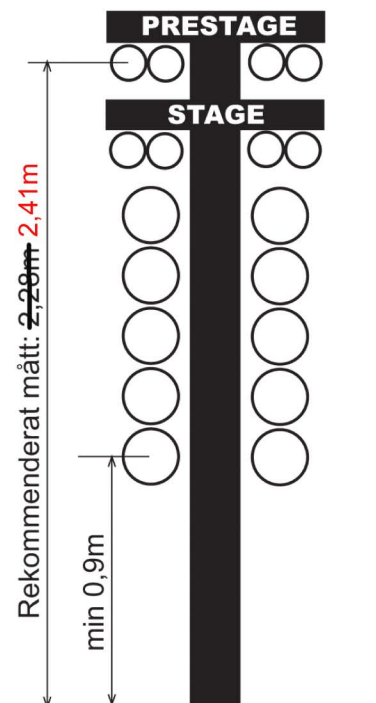

Figur 5. Banmått

